

Description

This type of ball float steam trap with integral automatic air venting facility is designed for using the place where much amount of drain is expected such as heat exchangers, dryers or heaters. This trap has simple construction and reliable operation due to their lever float type, with Cast Steel body. It is available in horizontal flanged connections.



Limiting Conditions

Body Design Conditions	PN40
PMO - Maximum Operating Pressure	32 kgf/cm ²
TMO - Maximum Operating Temperature	300 °C
PMA - Maximum Allowable Pressure	40 kgf/cm ²
TMA - Maximum Allowable Temperature	350 °C
Cold Hydraulic Test Pressure	60 kgf/cm ²

Operating Range

Δ PMX – Maximum differential pressure

Model	Δ PMX
882FT - 10	10 kgf/cm ²
882FT - 20	20 kgf/cm ²
882FT - 32	32 kgf/cm ²

Sizes and Pipe Connections

DN 40, 50 Flanged (ANSI B16.5)

Dimensions / Weights (Approximate) mm and kg

Size	A	B	C	F-F	Weight
DN40	160	120	260	320	40
DN50	160	120	260	320	42

Construction are a bit different according the sizes

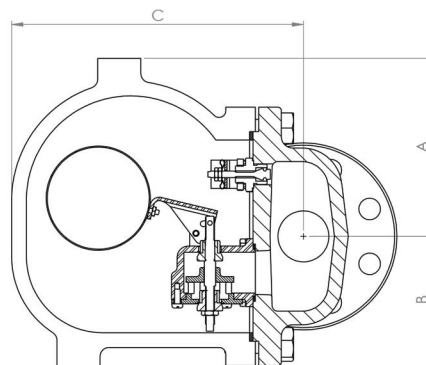



E.S.E. Valve Co. Ltd.

021 66479486

0912 8448763

فروش

E.S.E. Valve Co.

Ball Float Steam Traps - 882

Materials

No.	Part	Material
1	Body	ASTM A216 WCB
2	Valve Seat Gasket *	Reinforced Exfoliated Graphite
3	Valve Seat Assembly *	AISI 316
4	Bolt	Stainless Steel
5	Lever *	AISI 316
6	Pivot Pin	Stainless Steel
7	Ball Float *	AISI 316
8	Nut	Stainless Steel
9	Air Vent Assembly *	AISI 316
10	Cover Gasket *	Reinforced Exfoliated Graphite
11	Cover	ASTM A216 WCB
12	Bolt M16x1.5x50	ASTM F568M 10.9

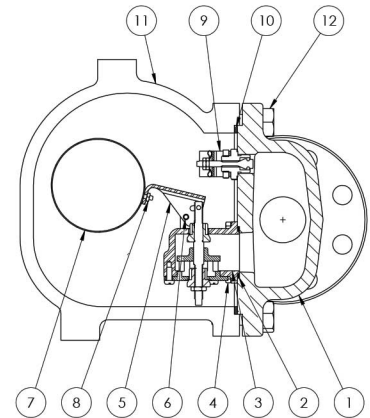

Note: (*) Spare Part

Capacities

Maximum continual discharge amount (Kg/h)

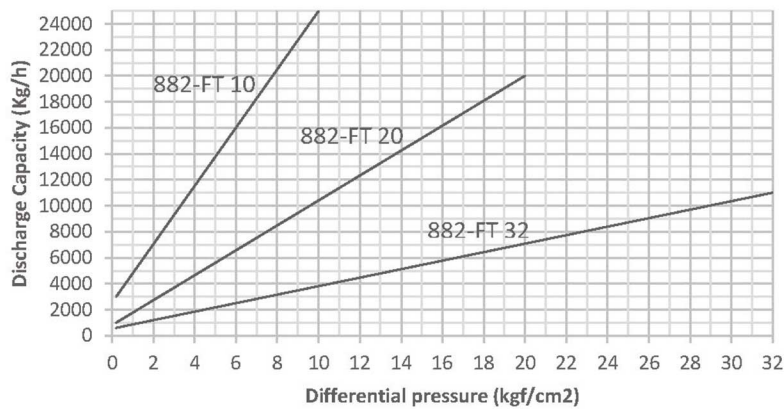

Note: Capacities shown are based on discharge at saturation temperature. In 882FT when discharging sub-cooled condensate, the air vent provides extra capacity. Under start up conditions, the air venting will be open, and will provide additional condensate capacity to outlet.

Installation

The trap should be installed in a horizontal pipeline with the direction of flow as indicated by the arrow on the trap body.

How to Order

Example: FT882 – DN40 - 20, Ball Float Steam Trap.

Design and specification are subject to change without notice